



Three Counties, Malvern, WR13 6NW
Floral Art Schedule

Closing date: 28th March 2022

RHS Malvern Spring Festival

5, 6, 7 & 8 May 2022

Floral Art Schedule

Judges: NAFAS

Pip Bensley

Michael Bowyer MBE

Jackie Charnock NDSF

Pam Fleming-Williams

Exhibits judged in accordance to NAFAS Competitions Manual (Third edition) 2015

Trophies: To be awarded to individual exhibitors

Best in Show (to be awarded to an individual) – The Gloria Lee Trophy - Donated by George Lee and Family

Reserve Best in Show – Donated by the Three Counties Floral Art Committee

Best Use of Fresh Foliage – Donated by Mrs Cate Morris

Best Use of Colour - Donated by the Three Counties Floral Art Committee

Best Young Arranger – Donated by Mr Malcolm Hodges

Best Junior – Donated by the Three Counties Floral Art Committee

Prizes:

Class 1	Judged by all 4 Judges, medal cards awarded.
Class 2	1 st - £50, 2 nd - £40, 3 rd - £30
Class 3	Judged by all 4 judges, medal cards awarded, £30 awarded if exhibit reaches required standard.
Class 4, 5, 6, 7, 8, 9 & 10	1 st - £40, 2 nd - £30, 3 rd - £20
Classes 11	1 st - £25, 2 nd - £20, 3 rd - £15
Classes 12, 13, 14	1 st - £35, 2 nd - £25, 3 rd - £20
Class 15 & 16	1 st - £10, 2 nd - £8, 3 rd - £5

Entry Fee – £5.00 per class (No entry fee for classes 1, 11, 15 and 16). Includes: Complimentary entry to the Show for Premier Day (Thursday) and 1 Sunday ticket and vehicle pass. Exhibitors entering only Classes 10, 12, 13, 14, 15 & 16 will receive 1 ticket which is valid for Sunday. Exhibitors aged 16 and under will receive a ticket for themselves and one for an accompanying adult. As entry numbers are limited, these will be treated in order of application. An SAE is required for acknowledgement of entry.

Use of the non-biodegradable (green coloured) floral foam is not allowed – disqualifications will be made.

Closing Date for entries **Monday 28 March 2022**

THEME – Wanderlust and Wonder

Class 1

Wanderlust and Wonder

An exhibit

- Staged on an unpainted base raised 31 cm above floor level.
- Space allowed: width 360 cm, depth 150 cm, height from floor including the base 275 cm.
- Background 244 cm high will be provided and painted pale blue. Title to be stated.
- **It is recommended exhibitors provide their own drapes/backcloth/base cloth and title.**
- To be staged by up to four people.
- To be viewed and judged from the front.
- To be judged using the medal award system.
- Please note Regulation 11.
- Limited to 5 exhibits.

Class 2

Paradise Found

An exhibit.

- Staged on a round base painted sage green, diameter 122 cm, height 10 cm.
- Space allowed: width 122 cm, depth 122 cm, height optional.
- To be staged by up to two people.
- Title to be included.
- To be viewed all round and judged from the front.
- Limited to 6 exhibits.

Class 3

Celebration

An exhibit

- Staged on an archway (painted black) and incorporating an chair (painted black) underneath the archway. Archway measurements: 229 cm height, 104 cm width and 52 cm depth. Chair measurements: width 41cm, depth 50cm, height 95cm, Seat width 39cm, depth 40cm and height 45cm.
- Centred within a marked space. Space allowed: width 150 cm, depth 100 cm, height 250cm.
- To be staged by up to two people. A title to be included.
- To be viewed all around and judged from the front.
- To be judged using the medal award system.
- Limited to 5 exhibits.

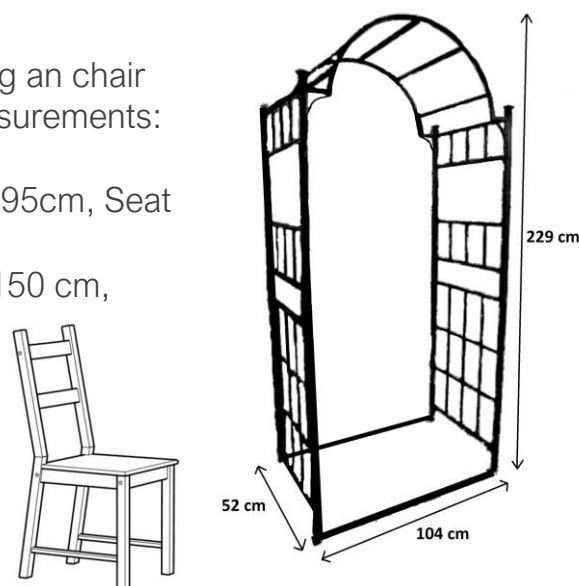

Use of the non-biodegradable (green coloured) floral foam is not allowed – disqualifications will be made.

Class 4

Let's Go Green

An exhibit.

- Staged on a corrugated cylinder, diameter 36 cm, height 60 cm from ground level.
- Space allowed: diameter 40cm, height from the top of the cylinder optional.
- Cylinder painted Dulux Oxford Blue.
- To be viewed and judged all round.
- Limited to 10 exhibits.

Class 5

Constellations

An exhibit

- Staged on a hanging grid at eye level.
- To be staged on a hanging grid, width 56 cm by length 91 cm, comprising of 5 cm squares.
- Space allowed: width 56cm, depth 30cm (15cm either side of grid), length 91cm. The approximate height from ground to the CENTRE of grid is 137 cm.
- Viewed and judged from both sides.
- Limited to 8 exhibits.

Class 6

The Great Barrier Reef

An exhibit

- Staged on a base raised 30 cm above floor level. To be staged within a triangular alcove measuring 100 cm height x 100 cm depth.
- Base painted white with mirrored sides.
- Judged from the front.
- Limited to 8 exhibits.

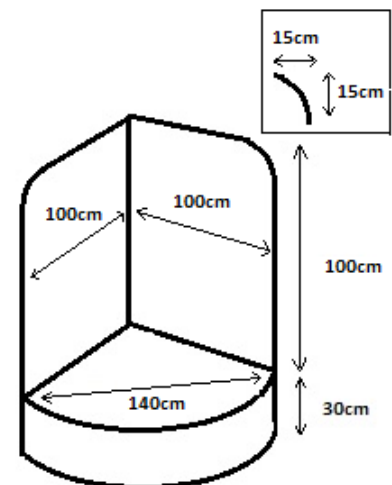

Class 7

Out of Africa

An exhibit

- Staged on a cube width 61 cm by depth 61 cm, height 56 cm.
- Space allowed: width 100 cm, depth 100 cm, height optional.
- Cube sides painted Dulux Moroccan Flame. Top of cube painted pale grey.
- To be viewed all round and judged from the front.
- Limited to 14 exhibits.

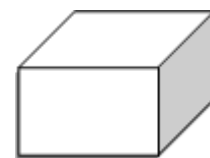

Use of the non-biodegradable (green coloured) floral foam is not allowed – disqualifications will be made.

Class 8

Festival

Pedestal exhibit.

- Staged on a raised continuous wooden platform, height 30 cm, with door painted sage green backdrop.
- Space allowed: width 122 cm, depth 122 cm, height optional.
- Exhibitor to provide own staging/mechanics.
- To be viewed and judged from the front.
- Limited to 12 exhibits.

Class 9

Upcycle

A Still Life exhibit.

- Staged on tabling 76 cm from floor and covered in green fabric.
- Space allowed: width 76 cm, depth 76 cm, height optional.
- To be viewed and judged from the front.
- Limited to 16 exhibits.

Class 10

Waterfall

An exhibit: A Free-Hanging exhibit

- Designed to be hung from a horizontal rail (provided) approximately 2m from ground level, hook provided.
- Space allowed: width 60 cm, depth 60 cm, maximum length 100cm.
- May be brought ready assembled.
- Artificial material may be used, natural plant material must predominate.
- To be viewed and judged all around.
- Limited to 8 exhibits.

NB: an entry in this class only entitles the competitor to one complimentary ticket (Sunday only).

Class 11

Flamboyant Fantasy

Open to ages Under 30 (age to be stated on entry form)

An exhibit

- Staged using a metal stand (provided) and measuring 1m high by 23 cm square (see diagram), standing on a circular base measuring 61 cm in diameter, with a grid top measuring 41 cm width x 61cm length (provided). All mechanics painted Dulux Purple Pout.
- Space allowed: 76cm width x 76cm depth, maximum height 30cm from top of grid.
- To be viewed and judged all round.
- Limited to 12 exhibits

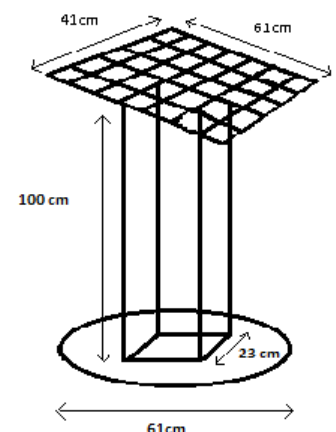

Use of the non-biodegradable (green coloured) floral foam is not allowed – disqualifications will be made.

Class 12

Theatre of Dreams

A Petite exhibit.

- Staged on blue/grey painted blocks (measuring 25.5 cm width, 25.5cm depth and 9.5cm height), on tabling 76cm from ground level.
- Space allowed: Not to exceed 25 cm in width, depth and height. Does not apply to diagonal measurement.
- May be brought ready assembled.
- To be viewed and judged from the front.
- Limited to 15 exhibits.

NB: an entry in this class only entitles the competitor to one complimentary ticket (Sunday only).

Class 13

Little Miracle

A Miniature exhibit.

- Staged on blue/grey painted coasters.
- Space allowed: Not to exceed 10 cm in width, depth and height. Does not apply to diagonal measurement.
- May be brought ready assembled.
- To be viewed and judged from the front.
- Limited to 15 exhibits.

NB: an entry in this class only entitles the competitor to one complimentary ticket (Sunday only).

Class 14

Carnival Mask

Craft exhibit: A Full Face Mask

- Space allowed: Not to exceed 40 cm in width and 40 cm in height.
- Designed to be hung.
- To be staged at the discretion of the committee against a Dulux Luscious Lime background.
- Natural plant material to predominate.
- Artificial materials may be used.
- May be brought ready assembled.
- To be viewed and judged from the front.
- Limited to 12 exhibits.

NB: an entry in this class only entitles the competitor to one complimentary ticket (Sunday only).

Use of the non-biodegradable (green coloured) floral foam is not allowed – disqualifications will be made.

Class 15 – Junior Class

Seaside

Open to ages under 12 (**age to be stated on entry form**)

An exhibit in a tray.

- Staged on tabling 76 cm from floor and covered in green fabric.
- Space allowed: Not to exceed 76 cm in width.
- May be brought ready assembled.
- To be viewed and judged from the front.
- **NB. Not judged under NAFAS Rules.**
- Limited to 16 exhibits.

NB: an entry in this class only entitles the competitor to one complimentary ticket (Sunday only).

Class 16 – Junior Class

Pack Your Case

Open to ages under 16 (**age to be stated on entry form**)

An exhibit in a suitcase.

- Staged on tabling 76 cm from floor and covered in green fabric.
- Space allowed: Not to exceed 76 cm in width.
- Exhibitor to provide a suitcase.
- Artificial materials may be used.
- To be viewed and judged from the front.
- Limited to 16 exhibits

NB: an entry in this class only entitles the competitor to one complimentary ticket (excludes Thursday).

Use of the non-biodegradable (green coloured) floral foam is not allowed – disqualifications will be made.

Regulations for All Classes

1. The competitors will be judged under the NAFAS Competitions Manual (Third edition) 2015.
2. **Exhibitors must arrange the exhibits in the building** without assistance with the exception of Classes 10, 12, 13, 14 and 15 which must be the unaided work of the exhibitor. **If in the stewards' opinion work is completed contra to NAFAS regulation the judging panel will be advised.** No exhibitor may enter more than one exhibit in any one class.
3. **Aerosol spray cans of any description must not be used inside the exhibition hall.**

4. Please consider the environmental impact of your exhibit. **The use of plastic-containing floral foam is prohibited.** Please choose environmentally responsible alternatives where possible. If you are using a degradable alternative to floral foam please contact the Floral Art Administrator to confirm that the product is suitable.
5. The position to be occupied by all exhibits shall be decided by the Three Counties Agricultural Society Floral Art Committee.
6. The Society will arrange **watering of exhibits** each day **if requested**. Competitors are asked to complete the form provided and to leave it with the organisers indicating where their exhibit should be watered, **and to ensure that any container has sufficient space for water.**
7. All the exhibitors' property will be at the risk of the exhibitor and the RHS Malvern Spring Festival (Three Counties Agricultural Society) will not be liable for the loss or damage for any cause whatsoever. It is advisable that any valuable accessory should be secured.
8. All entries must be made on the official entry form which must be received by the Floral Art Section not later than first post **Monday, 28 March 2022** Entries are limited in each class and should the number of entries for any class exceed the number that can be accommodated the competitor will be advised. Entries will be accepted on a first come, first served basis. Confirmation of entry will be sent within 14 days of closing date or, if they have been unsuccessful, the entry fee will be refunded. **A SAE must be included for acknowledgement of receipt of entry.** Otherwise no entry fee will be refunded and the Committee reserves the right to refuse any entry and in the event of a refusal, it is not required to give any reason.
9. Each entry must be accompanied by a fee of £5.00 per class. These fees include VAT. There is no entry fee for Classes 1, 11, 15 and 16. Cheques should be made payable to "Three Counties Agricultural Society" or "TCAS".
10. If exhibitors are unable to stage their exhibit/s please inform the Floral Art section by Friday, 15 April 2022. Please note that in the event of exhibitors being unable to stage their exhibits, no refunds will be given in order to cover an administration charge.
11. **Exhibits may be staged at any time between 10.30am on Wednesday 4th May 2022 and 5.00am on Thursday 5th May 2022. All exhibitors must leave the competition area by 5.15am on Thursday 5th May 2022, in preparation for judging at 5.30am, and will NOT be re-admitted until after judging is complete and the Show is open. N.B Class 1 exhibitors may have vehicle access from 09.30am on Wednesday 4th May 2022 to allow unloading of materials into the competition area; vehicles must then be removed and the staging may not commence until 10.30am.**
12. Each exhibitor will be notified of the number allocated to his/her exhibit. The exhibit must be staged in the space allocated at the discretion of the committee.
13. Exhibitors will not be allowed to remove exhibits before 5.15pm on Sunday, 8 May 2022. Vehicles must use the gate indicated by the colour of their vehicle pass to gain access to the area near the exhibition hall. Exhibitor's vehicles will be allowed on the showground between 10.30am on Wednesday 4th May and 06.30am on Thursday 5th May. **No vehicles will be re-admitted until after 6.15pm on Sunday.** Exhibitors should use the Public Parking areas during show hours.
14. Prize money will be forwarded after the show. Any prize may be withheld or modified if the exhibits are considered undeserving of the prizes offered.
15. Queries relating to the show generally should be directed to the Floral Art Administrator, Three Counties Showground, Tel. 01684 584900. Queries relating to this schedule should be directed to Mrs Christine Peer, Tel. 01684 310215.

RHS Malvern Spring Festival

Three Counties Showground, Malvern, Worcestershire WR13 6NW
Tel 01684 584900 Fax 01684 584910 Email: info@threecounties.co.uk